

### Performances 1400.8PG/PiG

#### DESIGN

The Performances range of rotisseries has been especially designed for high-volume cooking with high output and speed, while retaining excellent cooking quality. Well designed, user friendly and reliable the Performances is used by leading super-markets and chain restaurants throughout the world.

Conscious of the high energy cost involved for our clients, the Performances rotisserie has energy saving infrared burners, patented by Rotisol. A wide array of accessories enable the rapid roasting of a variety of products.

#### FEATURES

- Energy efficient
- Tempered K-glass doors
- Independent motor for each spit
- Equipped with bottom drip tray with built-in drainage
- Rotisol patented burners
- Powerful halogen lamp
- Delivered with 8 prongless spits (CUI1400)
- Illuminated sign «Rotisserie»
- Base on casters with brakes

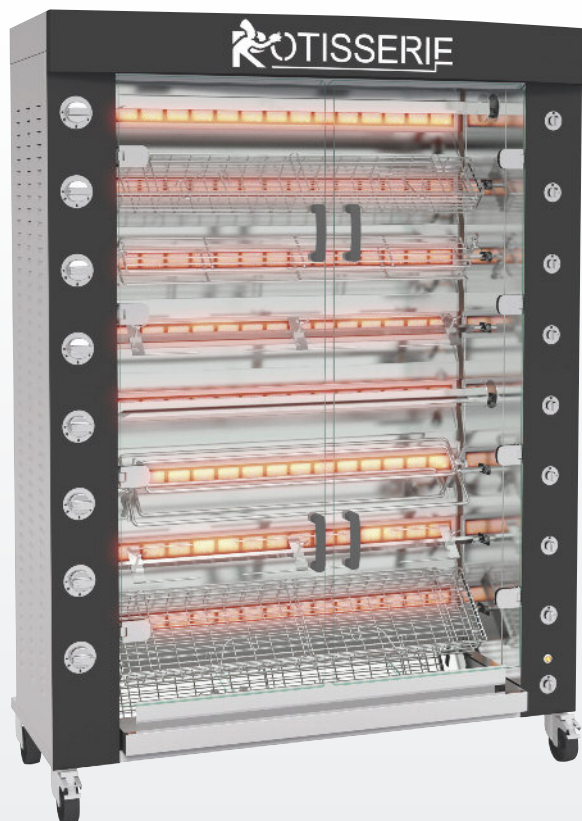

1400.8PG  
Black enamel



#### TECHNICAL DETAILS

Overview of some of the standard features.

	Replaceable ceramic bricks for significant financial savings		Robust hinges designed for heavy use, with integrated locking in open and closed positions		Gas safety ! separation of the gas and electric chambers avoids any risks of explosion
	Gas and electric switches, in chromed metal		Anti-scald K-glass reduces external thermal radiation (energy saving). Glass overlaps drip pan to keep splatters inside (anti-slip protection).		Removable inside side-panels doubles protection from grease seeping into motors and other sensitive parts

#### ACCESSORIES

A variety of accessories are available. See video of available [accessories](#) and of [vertical spit system](#) online.

<b>CUI1400</b> Anti-cutting prongless V-spit.		<b>PID1400</b> Tray for unspitting.		<b>BRC1400</b> Rectangular basket spit.	
<b>BS1400</b> Spit for ham / turkey.		<b>BRRO1400</b> Roast-clamp spit.		<b>BA1400</b> Lamb/suckling-pig spit.	
<b>BCR1400</b> Spatchcock chicken basket.		<b>DEC</b> Spit mover.		<b>AT</b> Gas lighter.	

### Front view

Rotisserie with roof (optional) and base on casters (optional)

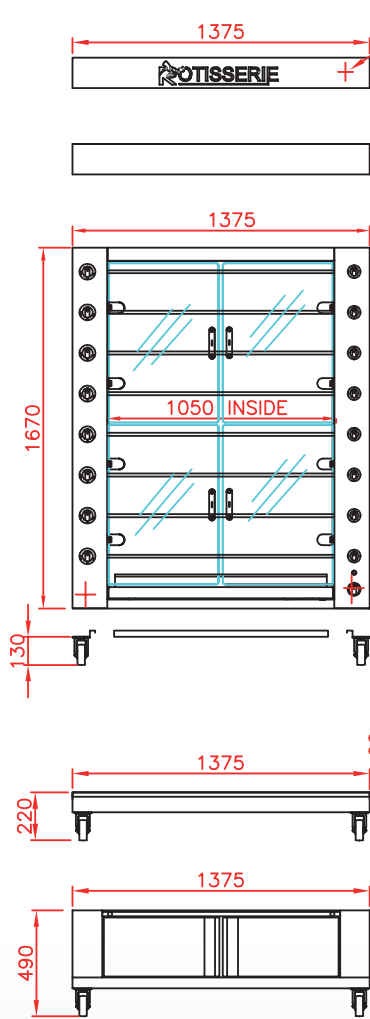

### Side view

Rotisserie with roof (optional) and base on casters (optional)

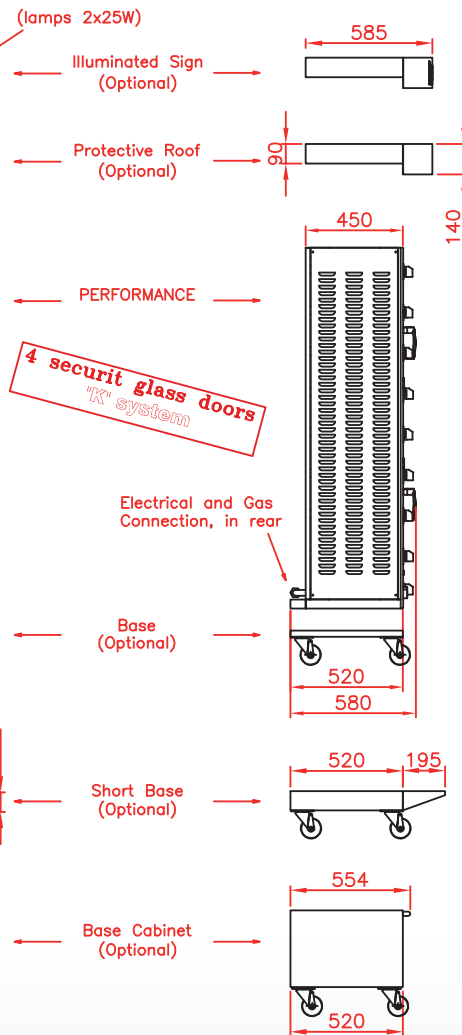

### Top view

Rotisserie with roof (optional) and base on casters (optional)

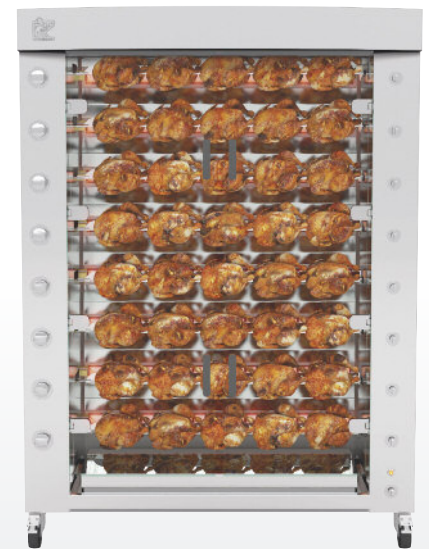
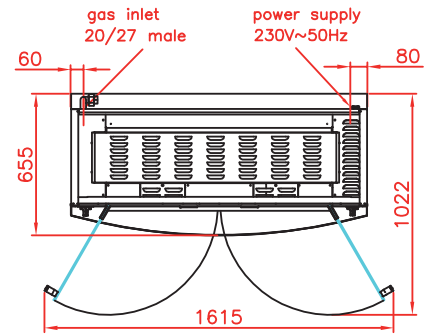

1400.8PiG  
Stainless steel



Revised :  
December 2016

## SPECIFICATIONS

Capacity	40/48 poultries
Gas power	44 kW
Power supply	208-230V-50Hz/60Hz
Electrical power	0.89 kW
Weight and size (HxDxW)	240 kg ; 1890 x 655 x 1375 mm
Shipping weight and size	301 kg ; 1900 x 770 x 1480 mm
Guarantee	1 year parts



DISTRIBUTOR / AGENT

Rotisol S.A.S.

Zone industrielle La Trentaine, Avenue Gustave Eiffel  
77507 Chelles cedex - FRANCE

[s.bennell@rotisol.com](mailto:s.bennell@rotisol.com) - Tel : +33 1 64 21 80 00

[www.rotisol.com](http://www.rotisol.com)